

SCHONBEK
Signature[™]

TEMPEST
S5602- ____ / ____ R

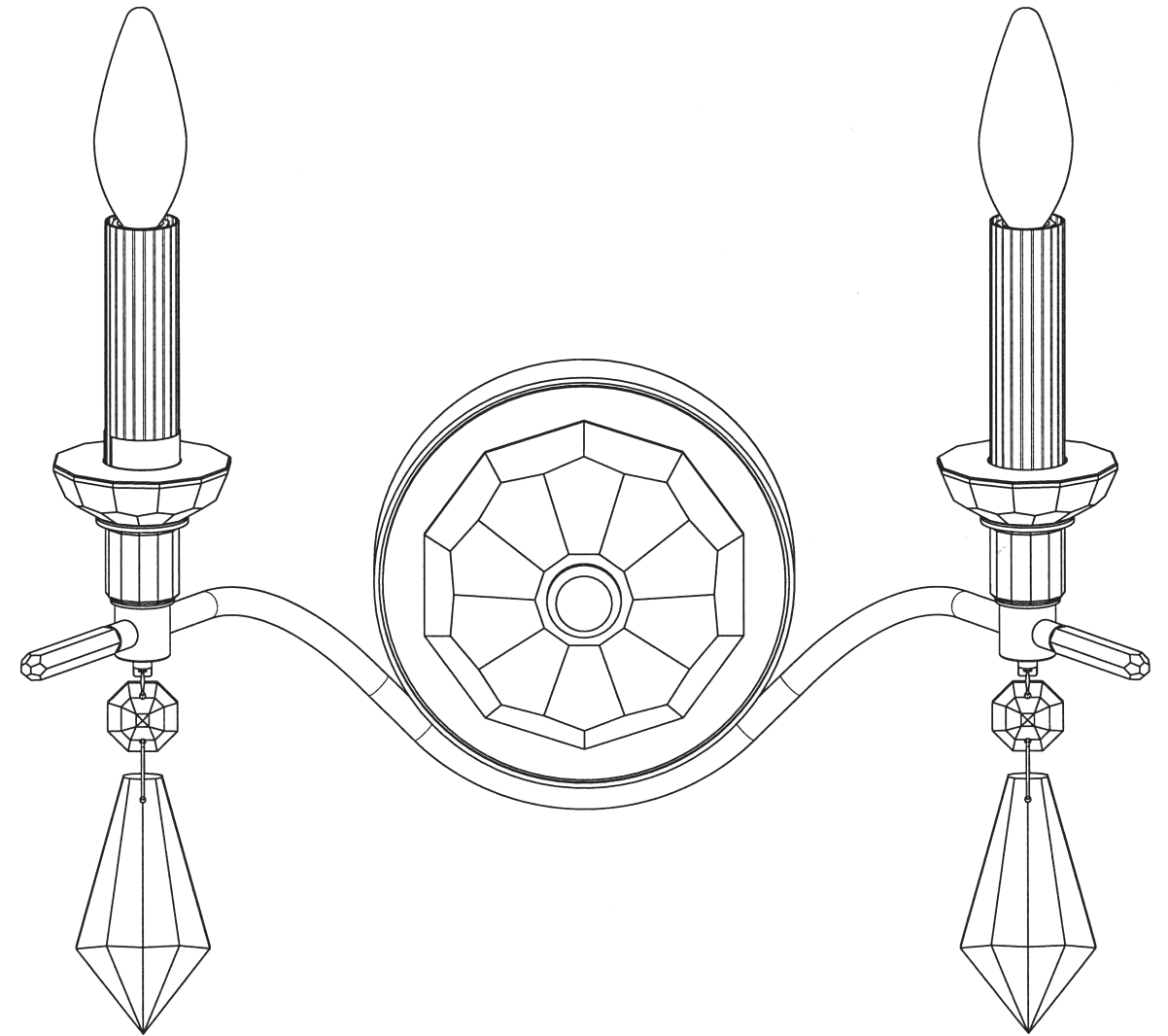

THIS DESIGN IS THE PROPRIETARY
TRADE DRESS/TRADEMARK OF
W SCHONBEK LLC.

SCHONBEK
Signature[™]

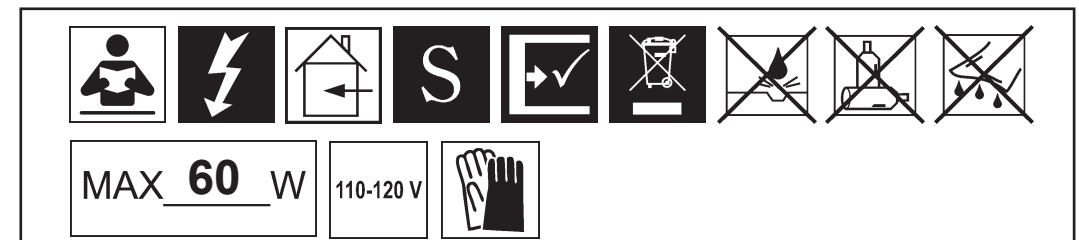

WARNING:

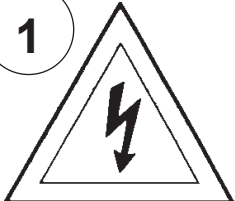
1  **Electrical Danger**

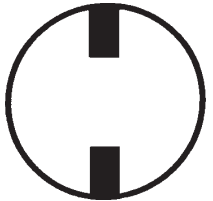
 **Turn Power Off**

All electrical components must be installed by a licensed electrician in accordance with the National Electric Code and the appropriate local electrical codes.

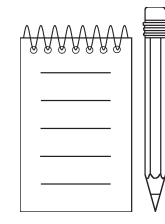
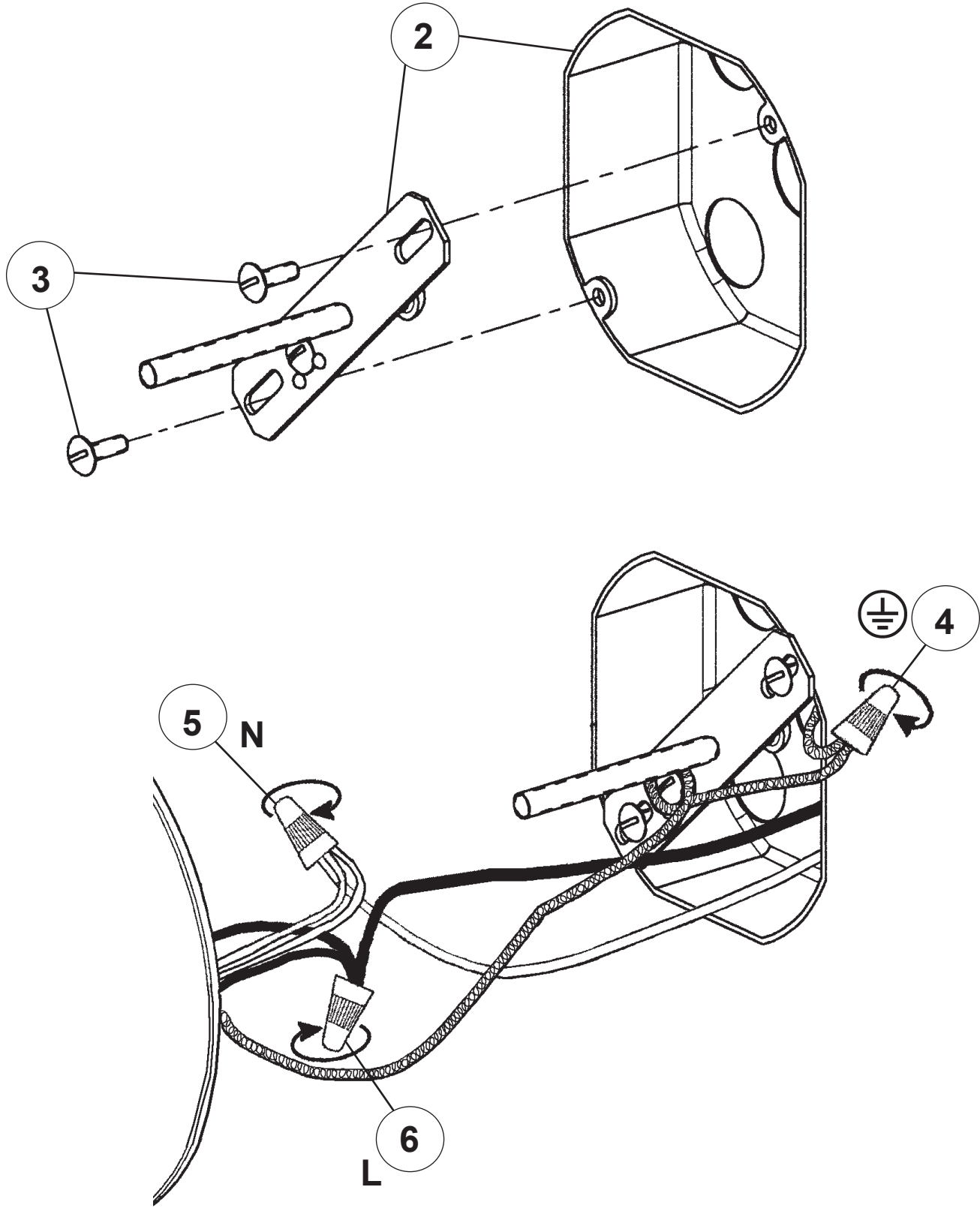

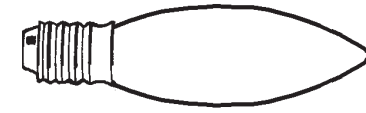
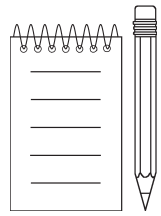

You will need 2 - B10
25 Watts Recommended
60 Watts Max

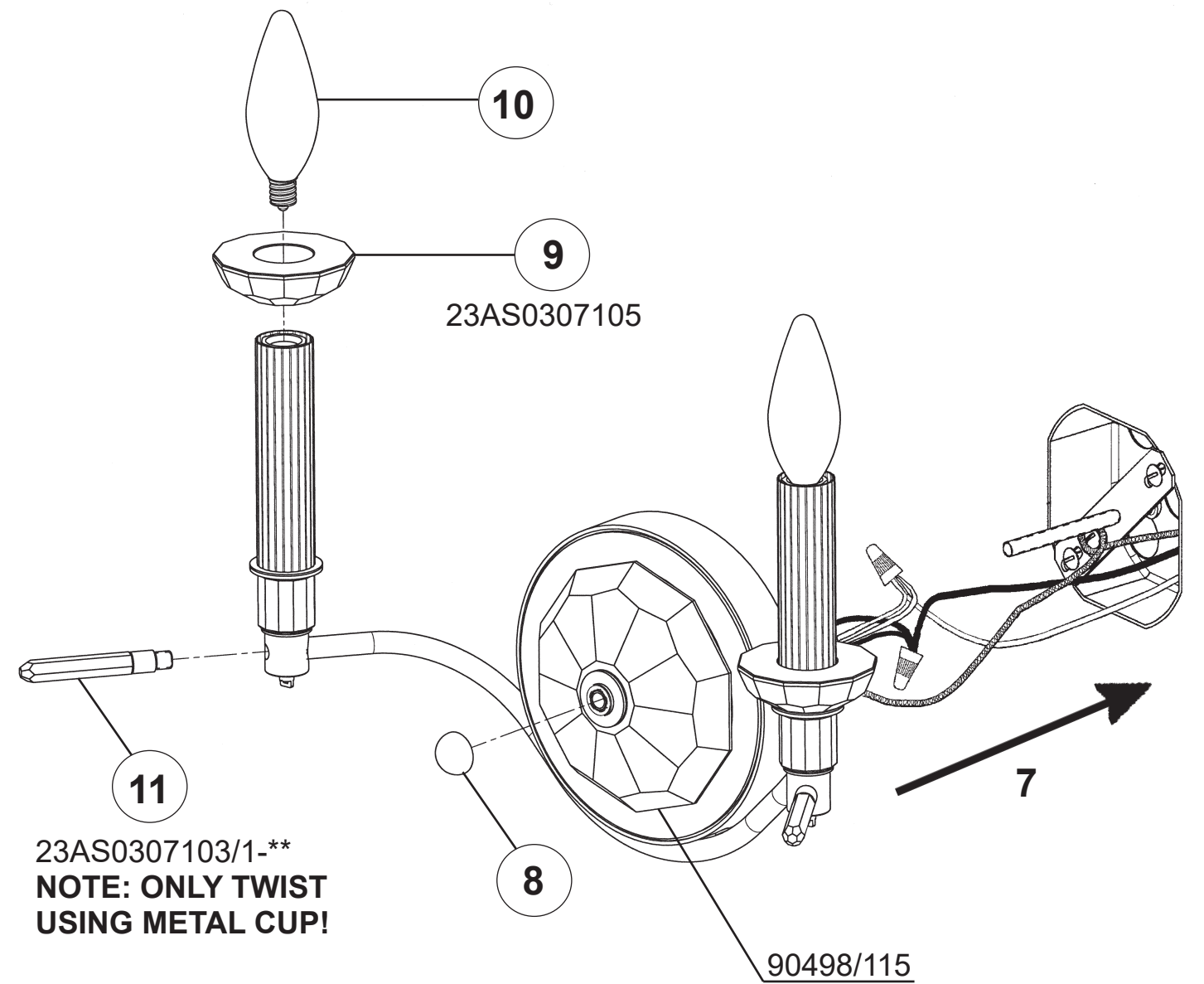

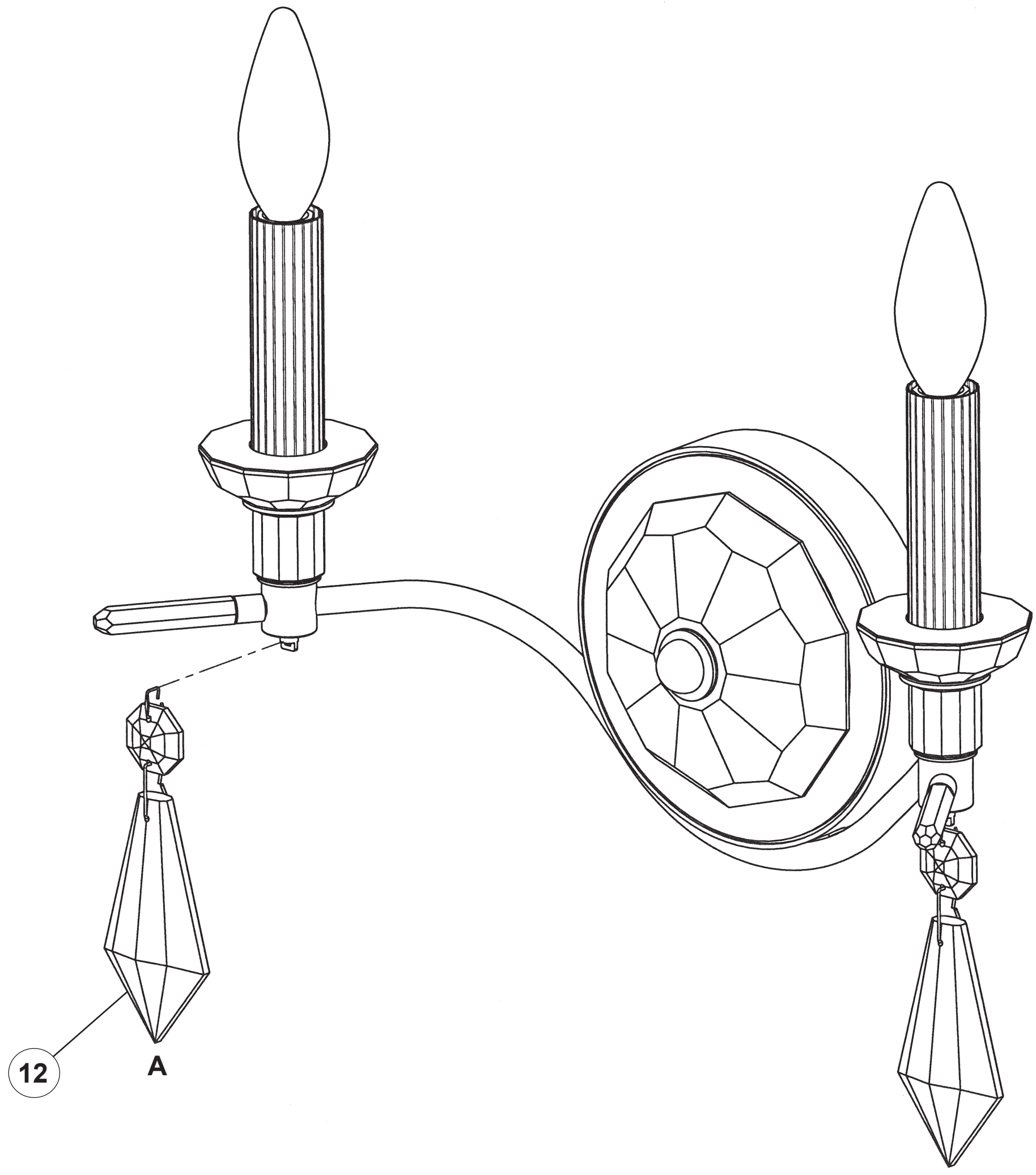

12

A