

SCHONBEK
*Signature*TM

TAMERLAINE
S92610-__ __R



THIS DESIGN IS THE PROPRIETARY
TRADE DRESS/TRADEMARK OF
W SCHONBEK LLC.

SCHONBEK
*Signature*TM

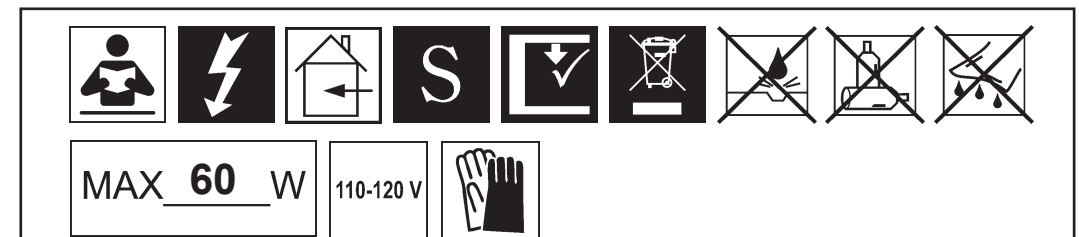

WARNING:

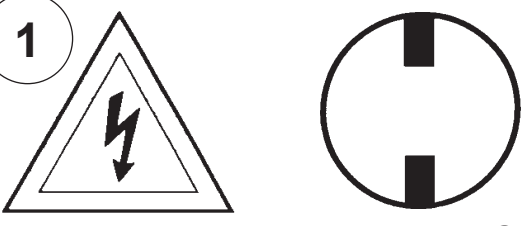
1 

Electrical Danger Turn Power Off

All electrical components must be installed by a licensed electrician in accordance with the National Electric Code and the appropriate local electrical codes.

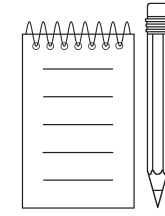
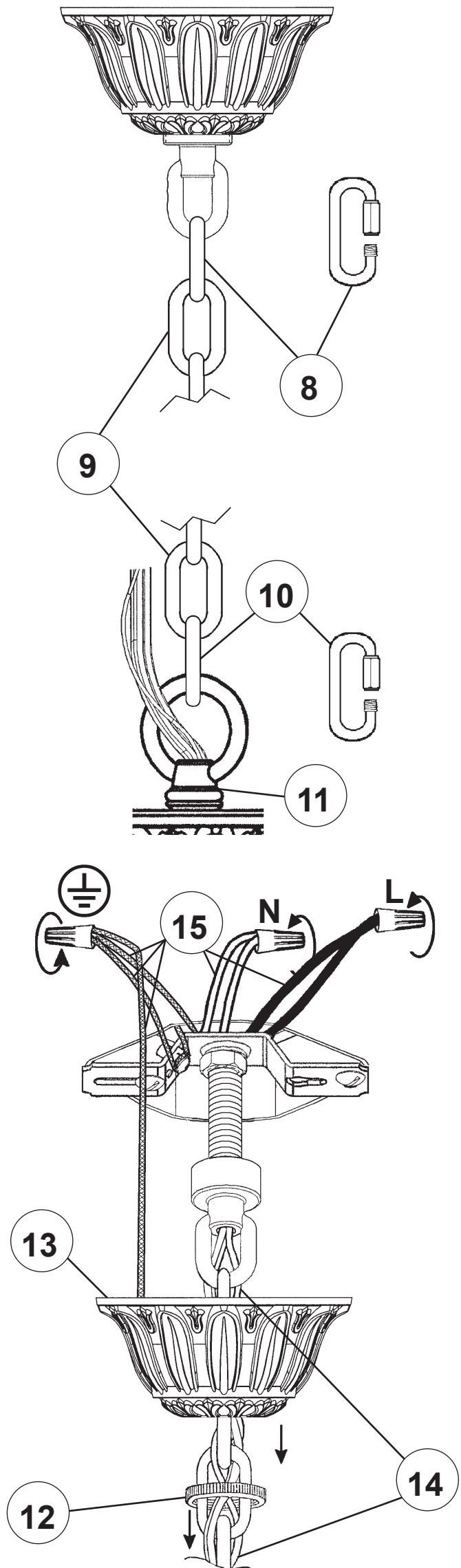
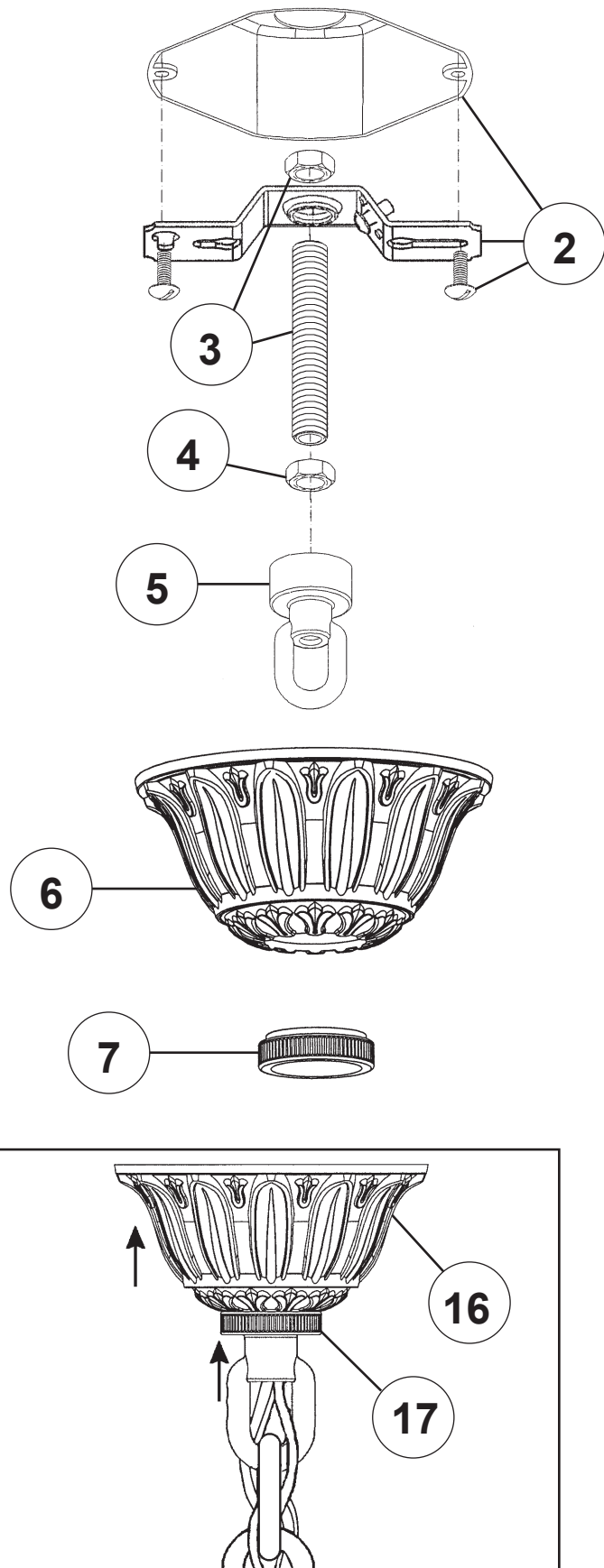

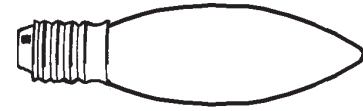
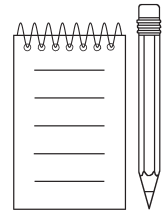

You will need 10 - B10
25 Watts Recommended
60 Watts Max

